

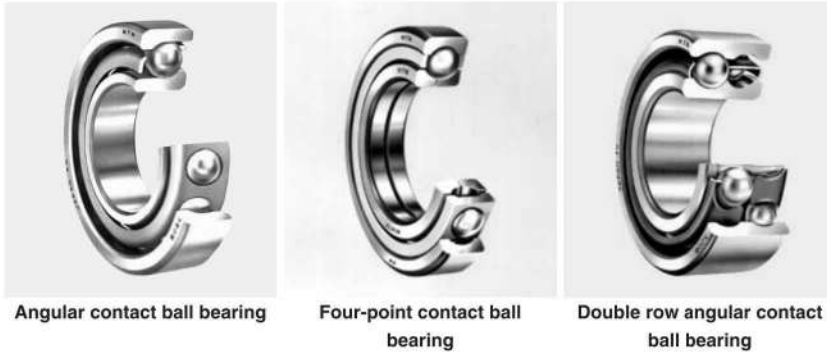

MORADI TOOS BALL BEARING



1. Design features and special characteristics

1.1 Angular contact ball bearing

Angular contact ball bearings are non-separable bearings which have a certain contact angle in the radial direction relative to the straight line that runs through the point where each ball makes contact with the inner and outer rings (see **Diagram 1**). **Table 1** gives contact angle and contact angle symbol.

In addition to radial loads, single direction axial loads can also be accommodated by angular contact ball bearings.

Furthermore, since an axial load is generated from a radial force, these bearings are generally used in pairs facing each other. Standard type, high speed use type and ultra high speed varieties of angular contact ball bearings are available through **MBR**, and there are also many duplex varieties. A bearing accuracy of JIS Class 5 or higher is applied to duplex type angular contact ball bearings, and in many cases they are given a preload, in compliance with standard preload levels,

before being used in an application. **Table 2** shows information concerning angular contact ball bearings, and **Table 3** shows similar information for duplex angular contact ball bearings.

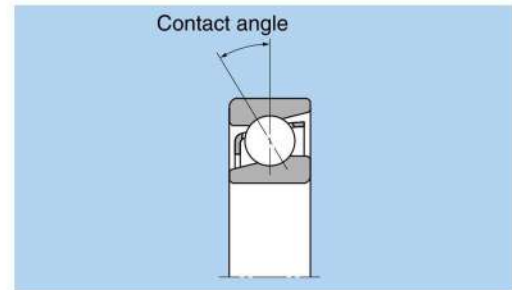

Diagram 1.

Table 1 Contact angle and contact angle codes

Contact angle	15°	30°	40°
Code	C	A ^①	B

① Contact angle symbol A is omitted.

Table 2 Angular contact ball bearing types and characteristics

Type	Design	Characteristics
Standard type		<ul style="list-style-type: none"> Available in bearing series 79, 70, 72, 72B, 73, and 73B. Contact angles: 30° and 40° (with B) available. Standard bearing cage type differs depending on bearing no. (Refer to Table 4)

Table 3 Duplex angular contact ball bearings — types and characteristics

Duplex type		Characteristics
Back-to-back duplex (DB)		<ul style="list-style-type: none"> Can accommodate radial loads and axial loads in either direction. Has a large distance l between the acting load center of the bearing, and therefore a large momentary force load capacity. Allowable misalignment angle is small.
Face-to face duplex (DF)		<ul style="list-style-type: none"> Can accommodate radial loads and axial loads in either direction. Has a smaller distance l between the acting load center of the bearing, and therefore a smaller momentary force load capacity. Has a larger allowable misalignment angle than back-to-back duplex type.
Tandem duplex (DT)		<ul style="list-style-type: none"> Can accommodate radial loads and single direction axial loads. Axial loads are received by both bearings as a set, and therefore heavy axial loads can be accommodated.

Note: 1. Duplex bearings are manufactured in a set to specified clearance and preload values, therefore they must be assembled together with identically numbered bearings and not mixed with other arrangements.

2. Triplex arrangements of angular contact bearings are also available. Consult **MBR** Engineering for details.

1.2 Four-point angular contact ball bearings

Four-point angular contact ball bearings have a contact angle of 30° and inner rings which are separated in half. As shown in **Diagram 2**, when the inner and outer rings receive a radial load the ball bearings contact the inner and outer rings at four points. This construction enables a single bearing to accommodate axial loads from either direction, and when generally under a simple axial load or heavy axial load, the bearing functions in reliance on two contact points like ordinary bearings.

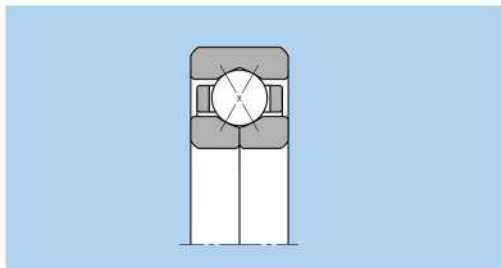

Diagram 2.

1.3 Double row angular contact ball bearings

The structure of double row angular contact ball bearings is designed by arranging two single row angular contact bearings back-to-back in duplex (DB) to form one united bearing with a contact angle of 25°.

These bearings are capable of accommodating radial loads, axial loads in either direction, and have a high capacity for momentary loads as well.

As shown in **Diagram 3**, sealed and shielded type double row angular contact ball bearings are also available. Standard loads vary from those of open type bearings.

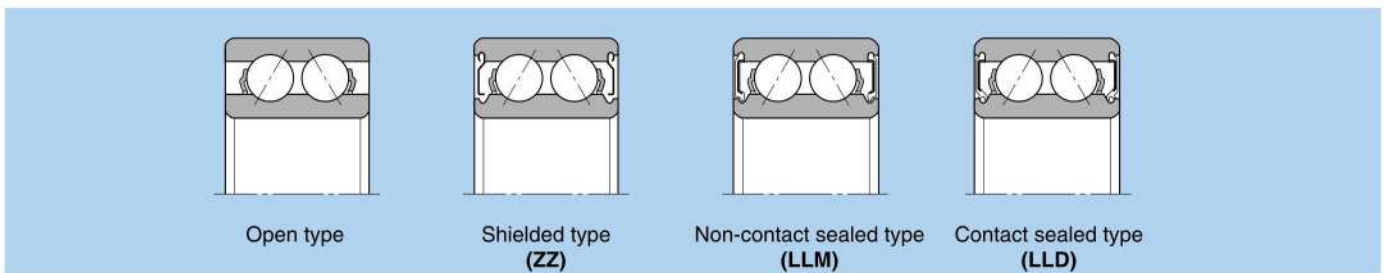

Diagram 3.

■ Flush ground

"Flush ground" is the name given to the finishing method shown in **Diagram 4** where the offset of the front and back faces of the bearing are ground to the same value. By doing this, a stated clearance or preload value can be achieved by using bearings with identical codes for these values, in other words by combining either DB or DF series bearings. DT series bearings can also be used in various arrangements to achieve uniform load distribution.

All BNT type bearings are flush ground, but other angular contact ball bearing series are not. If it is necessary to flush grind any of these other bearings, please consult MBR Engineering.

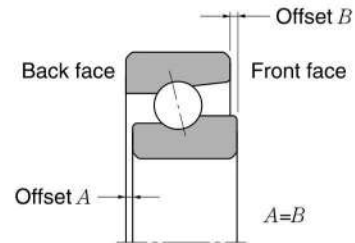

Diagram 4.

2. Standard cage types

Table 4 lists the standard cage types for angular contact ball bearings.

Table 4 Standard cages for angular contact ball bearings

Type	Bearing series	Molded resin cage	Pressed cage	Machined cage
Standard	79	7904~7913	—	7914 ~7960
	70	7000~7024	—	7026 ~7040
	72	—	7200 ~7222	7224 ~7240
	73	—	7300 ~7322	7324 ~7340
	72B	—	7200B~7222B	7224B ~7240B
	73B	—	7300B~7322B	7324B ~7340B
4-point contact	QJ2	—	—	QJ208 ~QJ224
	QJ3	—	—	QJ306 ~QJ324
Double row	52	—	5200S~5217S	—
	53	—	5302S~5314S	—

Note: Due to the material characteristics of molded resin cages, use at application temperatures in excess of 120°C is not possible.



Single and Duplex Angular Contact Ball Bearings

MBR

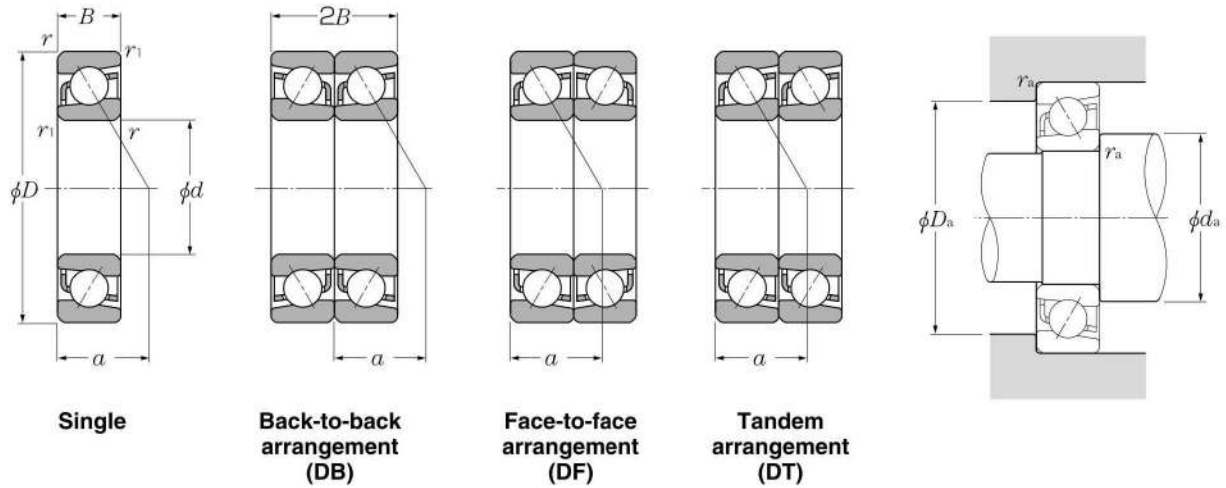

d 10 ~ 30mm

d	Boundary dimensions					Basic load ratings				Limiting speeds ¹⁾		Bearing ²⁾ numbers	Load center mm a	Mass kg single (approx.)
	D	B	2B	r _s min ³⁾	r _s min ³⁾	dynamic		static		grease	oil			
	mm					kN		kgf		min ⁻¹				
10	26	8	16	0.3	0.15	4.65	2.07	470	212	29 000	39 000	7000	9	0.023
	30	9	18	0.6	0.3	5.45	2.74	555	279	28 000	37 000	7200	10.5	0.029
	30	9	18	0.6	0.3	5.00	2.52	510	257	24 000	32 000	7200B	13	0.029
	35	11	22	0.6	0.3	10.1	4.95	1 030	500	26 000	34 000	7300	12	0.04
	35	11	22	0.6	0.3	9.50	4.60	970	470	22 000	29 000	7300B	15	0.041
12	28	8	16	0.3	0.15	5.05	2.46	515	251	26 000	35 000	7001	10	0.025
	32	10	20	0.6	0.3	7.60	3.95	775	405	25 000	33 000	7201	11.5	0.035
	32	10	20	0.6	0.3	7.00	3.65	775	405	21 000	28 000	7201B	14	0.036
	37	12	24	1	0.6	11.2	5.25	1 140	535	23 000	30 000	7301	13	0.044
	37	12	24	1	0.6	10.5	4.95	1 080	505	19 000	26 000	7301B	16.5	0.045
15	32	9	18	0.3	0.15	5.80	3.15	590	320	23 000	31 000	7002	11.5	0.035
	35	11	22	0.6	0.3	9.05	4.70	925	480	22 000	29 000	7202	12.5	0.046
	35	11	22	0.6	0.3	8.35	4.35	855	445	18 000	25 000	7202B	16	0.046
	42	13	26	1	0.6	13.5	7.20	1 370	735	19 000	26 000	7302	15	0.055
	42	13	26	1	0.6	12.5	6.65	1 270	680	17 000	22 000	7302B	19	0.057
17	35	10	20	0.3	0.15	7.15	3.85	730	390	21 000	28 000	7003	12.5	0.046
	40	12	24	0.6	0.3	12.0	6.60	1 220	675	19 000	26 000	7203	14.5	0.064
	40	12	24	0.6	0.3	11.0	6.10	1 120	625	17 000	22 000	7203B	18	0.066
	47	14	28	1	0.6	15.9	8.65	1 630	880	18 000	24 000	7303	16	0.107
	47	14	28	1	0.6	14.8	8.00	1 510	820	15 000	20 000	7303B	20.5	0.109
20	42	12	24	0.6	0.3	9.70	5.60	990	570	19 000	25 000	7004	15	0.08
	47	14	28	1	0.6	14.5	8.40	1 480	855	17 000	23 000	7204	17	0.1
	47	14	28	1	0.6	13.3	7.70	1 360	785	15 000	20 000	7204B	21.5	0.102
	52	15	30	1.1	0.6	18.7	10.4	1 910	1 060	16 000	21 000	7304	18	0.138
	52	15	30	1.1	0.6	17.3	9.65	1 770	985	13 000	18 000	7304B	22.5	0.141
25	42	9	18	0.3	0.15	7.15	4.95	730	505	17 000	22 000	7905	14	0.05
	47	12	24	0.6	0.3	10.7	6.85	1 100	700	16 000	21 000	7005	16.5	0.093
	52	15	30	1	0.6	16.2	10.3	1 650	1 050	14 000	19 000	7205	19	0.125
	52	15	30	1	0.6	14.8	9.40	1 510	960	12 000	16 000	7205B	24	0.129
	62	17	34	1.1	0.6	26.4	15.8	2 690	1 610	13 000	17 000	7305	21	0.23
	62	17	34	1.1	0.6	24.4	14.6	2 490	1 490	11 000	15 000	7305B	27	0.234
30	47	9	18	0.3	0.15	7.55	5.75	770	585	14 000	19 000	7906	15.5	0.058
	55	13	26	1	0.6	13.9	9.45	1 410	965	13 000	18 000	7006	19	0.135

1) This value achieved with machined cages; when pressed cages are used, 80% of this value is acceptable.

2) Bearing numbers appended with the code "B" have a contact angle of 40°; bearings with this code have a contact angle of 30°.

3) Smallest allowable dimension for chamfer dimension r.

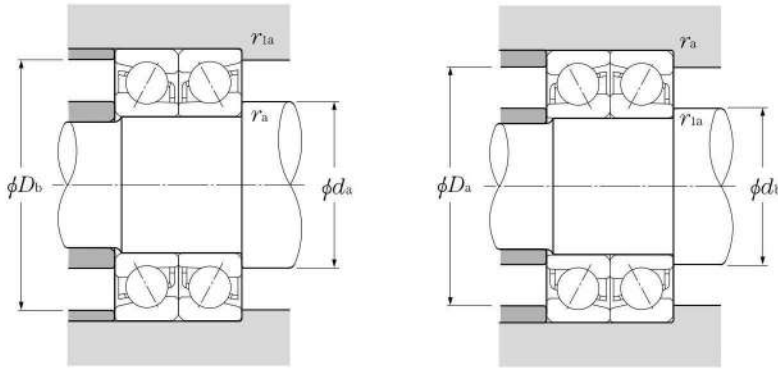

Dynamic equivalent radial load

$$P_r = X F_r + Y F_a$$

Contact angle	e	Single, DT				DB, DF			
		$F_a/F_r \leq e$		$F_a/F_r > e$		$F_a/F_r \leq e$		$F_a/F_r > e$	
		X	Y	X	Y	X	Y	X	Y
30°	0.80	1	0	0.39	0.76	1	0.78	0.63	1.24
40°	1.14	1	0	0.35	0.57	1	0.55	0.57	0.93

Static equivalent radial load

$$P_{or} = X_o F_r + Y_o F_a$$

Contact angle	Single, DT		DB, DF	
	X_o	Y_o	X_o	Y_o
30°	0.5	0.33	1	0.66
40°	0.5	0.26	1	0.52

For single and DT arrangement,

When $P_{or} < F_r$ use $P_{or} = F_r$

Basic load ratings				Limiting speeds ¹⁾		Bearing numbers ²⁾			Abutment and fillet dimensions					
dynamic (duplex) kN	static kN	dynamic (duplex) kgf	static (duplex) kgf	(duplex) min ⁻¹		DB	DF	DT	mm					
C_r	C_{or}	C_r	C_{or}	grease	oil				d_a min	d_b min	D_a max	D_b max	r_{as} max	r_{1as} max
7.50	4.15	765	425	23 000	31 000	DB	DF	DT	12.5	12.5	23.5	24.8	0.3	0.15
8.80	5.45	900	560	22 000	30 000	DB	DF	DT	14.5	12.5	25.5	27.5	0.6	0.3
8.10	5.05	825	515	19 000	26 000	DB	DF	DT	14.5	12.5	25.5	27.5	0.6	0.3
16.5	9.85	1 680	1 000	20 000	27 000	DB	DF	DT	14.5	12.5	30.5	32.5	0.6	0.3
15.4	9.20	1 570	940	18 000	24 000	DB	DF	DT	14.5	12.5	30.5	32.5	0.6	0.3
8.20	4.90	840	500	21 000	28 000	DB	DF	DT	14.5	14.5	25.5	26.8	0.3	0.15
12.3	7.95	1 260	810	20 000	26 000	DB	DF	DT	16.5	14.5	27.5	29.5	0.6	0.3
11.4	7.35	1 160	750	17 000	23 000	DB	DF	DT	16.5	14.5	27.5	29.5	0.6	0.3
18.2	10.5	1 850	1 070	18 000	24 000	DB	DF	DT	17.5	16.5	31.5	32.5	1	0.6
17.1	9.90	1 750	1 010	16 000	21 000	DB	DF	DT	17.5	16.5	31.5	32.5	1	0.6
9.40	6.30	960	640	18 000	24 000	DB	DF	DT	17.5	17.5	29.5	30.8	0.3	0.15
14.7	9.40	1 500	960	17 000	23 000	DB	DF	DT	19.5	17.5	30.5	32.5	0.6	0.3
13.6	8.70	1 390	885	15 000	20 000	DB	DF	DT	19.5	17.5	30.5	32.5	0.6	0.3
21.9	14.4	2 230	1 470	15 000	21 000	DB	DF	DT	20.5	19.5	36.5	37.5	1	0.6
20.3	13.3	2 070	1 360	13 000	18 000	DB	DF	DT	20.5	19.5	36.5	37.5	1	0.6
11.6	7.65	1 190	780	17 000	22 000	DB	DF	DT	19.5	19.5	32.5	33.8	0.3	0.15
19.4	13.2	1 980	1 350	15 000	21 000	DB	DF	DT	21.5	19.5	35.5	37.5	0.6	0.3
17.9	12.2	1 830	1 250	13 000	18 000	DB	DF	DT	21.5	19.5	35.5	37.5	0.6	0.3
25.9	17.3	2 640	1 760	14 000	19 000	DB	DF	DT	22.5	21.5	41.5	42.5	1	0.6
24.0	16.0	2 450	1 640	12 000	16 000	DB	DF	DT	22.5	21.5	41.5	42.5	1	0.6
15.8	11.2	1 610	1 140	15 000	20 000	DB	DF	DT	24.5	24.5	37.5	39.5	0.6	0.3
23.6	16.8	2 400	1 710	14 000	18 000	DB	DF	DT	25.5	24.5	41.5	42.5	1	0.6
21.6	15.4	2 200	1 570	12 000	16 000	DB	DF	DT	25.5	24.5	41.5	42.5	1	0.6
30.5	20.8	3 100	2 130	12 000	17 000	DB	DF	DT	27	24.5	45	47.5	1	0.6
28.2	19.3	2 870	1 970	11 000	14 000	DB	DF	DT	27	24.5	45	47.5	1	0.6
11.6	9.95	1 180	1 010	13 000	18 000	DB	DF	DT	27.5	27.5	39.5	40.8	0.3	0.15
17.5	13.7	1 780	1 400	12 000	17 000	DB	DF	DT	29.5	29.5	42.5	44.5	0.6	0.3
26.3	20.6	2 690	2 100	11 000	15 000	DB	DF	DT	30.5	29.5	46.5	47.5	1	0.6
24.0	18.8	2 450	1 920	10 000	13 000	DB	DF	DT	30.5	29.5	46.5	47.5	1	0.6
43.0	31.5	4 400	3 250	10 000	14 000	DB	DF	DT	32	29.5	55	57.5	1	0.6
39.5	29.3	4 050	2 980	9 100	12 000	DB	DF	DT	32	29.5	55	57.5	1	0.6
12.3	11.5	1 250	1 170	12 000	15 000	DB	DF	DT	32.5	32.5	44.5	45.8	0.3	0.15
22.5	18.9	2 300	1 930	11 000	14 000	DB	DF	DT	35.5	35.5	49.5	50.5	1	0.6

Note: For bearing series 79 and 70, inner rings are constructed with groove abutments on both sides. Therefore, the inner ring chamfer dimension r_1 is identical to dimension r . Furthermore, the radius r_{1a} of the shaft corner roundness is likewise identical to r_{1s} .

Single and Duplex Angular Contact Ball Bearings

MBR

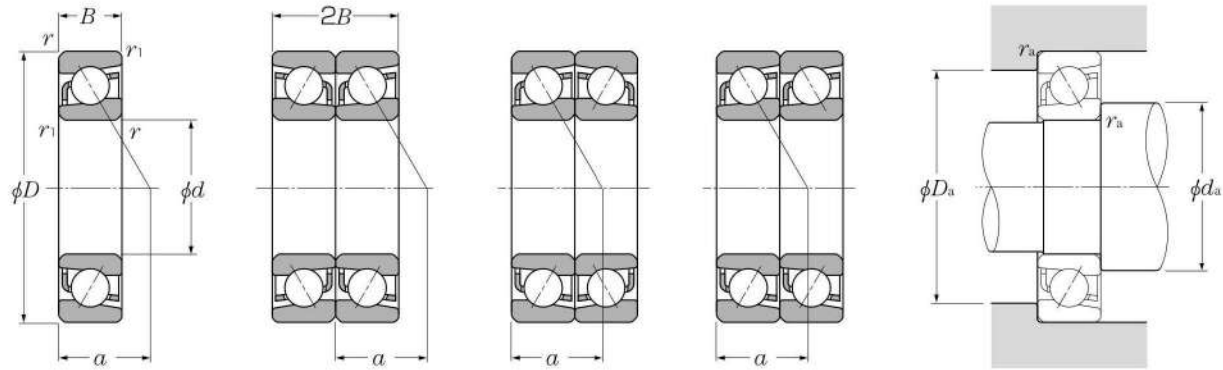

Single

Back-to-back arrangement (DB)

Face-to-face arrangement (DF)

Tandem arrangement (DT)

d 30 ~ 55mm

d	Boundary dimensions					Basic load ratings				Limiting speeds ¹⁾		Bearing numbers	Load center mm a	Mass kg single (approx.)
	D	B	2B	$r_{s \min}^{(3)}$	$r_{rs \min}^{(3)}$	dynamic kN C_r	static C_{or}	dynamic kgf C_r	static C_{or}	grease	oil			
30	62	16	32	1	0.6	22.5	14.8	2 300	1 510	12 000	16 000	7206	21.5	0.193
	62	16	32	1	0.6	20.5	13.5	2 090	1 380	11 000	14 000	7206B	27.5	0.197
	72	19	38	1.1	0.6	33.5	22.3	3 450	2 280	11 000	15 000	7306	24.5	0.345
	72	19	38	1.1	0.6	31.0	20.5	3 150	2 090	9 600	13 000	7306B	31.5	0.352
35	55	10	20	0.6	0.3	12.0	8.85	1 220	905	13 000	17 000	7907	18	0.088
	62	14	28	1	0.6	17.5	12.6	1 790	1 280	12 000	16 000	7007	21	0.18
	72	17	34	1.1	0.6	29.7	20.1	3 050	2 050	11 000	14 000	7207	24	0.281
	72	17	34	1.1	0.6	27.1	18.4	2 760	1 870	9 300	12 000	7207B	31	0.287
	80	21	42	1.5	1	40.0	26.3	4 050	2 680	9 800	13 000	7307	27	0.462
	80	21	42	1.5	1	36.5	24.2	3 750	2 470	8 400	11 000	7307B	34.5	0.469
40	62	12	24	0.6	0.3	12.7	10.2	1 290	1 040	11 000	15 000	7908	20.5	0.13
	68	15	30	1	0.6	18.8	14.6	1 910	1 490	10 000	14 000	7008	23	0.222
	80	18	36	1.1	0.6	35.5	25.1	3 600	2 560	9 600	13 000	7208	26.5	0.355
	80	18	36	1.1	0.6	32.0	23.0	3 250	2 340	8 300	11 000	7208B	34	0.375
	90	23	46	1.5	1	49.0	33.0	5 000	3 350	8 600	12 000	7308	30.5	0.625
	90	23	46	1.5	1	45.0	30.5	4 550	3 100	7 400	9 900	7308B	39	0.636
45	68	12	24	0.6	0.3	15.7	12.9	1 600	1 310	10 000	14 000	7909	22.5	0.15
	75	16	32	1	0.6	22.3	17.7	2 270	1 800	9 500	13 000	7009	25.5	0.282
	85	19	38	1.1	0.6	39.5	28.7	4 050	2 930	8 700	12 000	7209	28.5	0.404
	85	19	38	1.1	0.6	36.0	26.2	3 650	2 680	7 400	9 900	7209B	37	0.41
	100	25	50	1.5	1	63.5	44.0	6 450	4 500	7 800	10 000	7309	33.5	0.837
	100	25	50	1.5	1	58.5	40.0	5 950	4 100	6 600	8 900	7309B	43.0	0.854
50	72	12	24	0.6	0.3	16.6	14.5	1 690	1 470	9 200	12 000	7910	23.5	0.157
	80	16	32	1	0.6	23.7	20.1	2 410	2 050	8 600	11 000	7010	27	0.306
	90	20	40	1.1	0.6	41.5	31.5	4 200	3 200	7 900	10 000	7210	30	0.457
	90	20	40	1.1	0.6	37.5	28.6	3 800	2 920	6 700	9 000	7210B	39.5	0.466
	110	27	54	2	1	74.5	52.5	7 600	5 350	7 100	9 400	7310	36.5	1.09
	110	27	54	2	1	68.0	48.0	6 950	4 950	6 000	8 100	7310B	47	1.11
55	80	13	26	1	0.6	17.3	16.1	1 770	1 640	8 400	11 000	7911	26	0.214
	90	18	36	1.1	0.6	31.0	26.3	3 150	2 680	7 900	11 000	7011	30	0.447
	100	21	42	1.5	1	51.0	39.5	5 200	4 050	7 100	9 500	7211	33	0.6
	100	21	42	1.5	1	46.5	36.0	4 700	3 700	6 100	8 200	7211B	43	0.612
	120	29	58	2	1	86.0	61.5	8 750	6 300	6 400	8 600	7311	40	1.39
	120	29	58	2	1	79.0	56.5	8 050	5 800	5 500	7 300	7311B	52	1.42

1) This value achieved with machined cages; when pressed cages are used, 80% of this value is acceptable.

2) Bearing numbers appended with the code "B" have a contact angle of 40°; bearings with this code have a contact angle of 30°.

3) Smallest allowable dimension for chamfer dimension r or r_1 .

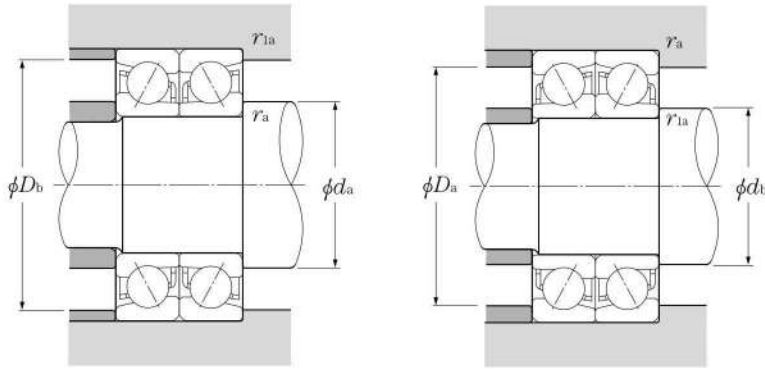

Dynamic equivalent radial load

$$P_r = X F_r + Y F_a$$

Contact angle	e	Single, DT				DB, DF			
		$F_a/F_r \leq e$		$F_a/F_r > e$		$F_a/F_r \leq e$		$F_a/F_r > e$	
		X	Y	X	Y	X	Y	X	Y
30°	0.80	1	0	0.39	0.76	1	0.78	0.63	1.24
40°	1.14	1	0	0.35	0.57	1	0.55	0.57	0.93

Static equivalent radial load

$$P_{or} = X_o F_r + Y_o F_a$$

Contact angle	Single, DT		DB, DF	
	X_o	Y_o	X_o	Y_o
30°	0.5	0.33	1	0.66
40°	0.5	0.26	1	0.52

For single and DT arrangement,
When $P_{or} < F_r$ use $P_{or} = F_r$

Basic load ratings				Limiting speeds ¹⁾		Bearing numbers ²⁾			Abutment and fillet dimensions					
dynamic (duplex) kN	static C_{or}	dynamic (duplex) kgf	static C_{or}	(duplex) min ⁻¹		DB	DF	DT	mm					
C_r	C_{or}	C_r	C_{or}	grease	oil				d_a min	d_b min	D_a max	D_b max	r_{as} max	r_{ias} max
36.5	29.6	3 750	3 000	9 800	13 000	DB	DF	DT	35.5	34.5	56.5	57.5	1	0.6
33.5	27.1	3 400	2 760	8 600	11 000	DB	DF	DT	35.5	34.5	56.5	57.5	1	0.6
54.5	44.5	5 550	4 550	8 900	12 000	DB	DF	DT	37	34.5	65	67.5	1	0.6
50.0	41.0	5 100	4 200	7 700	10 000	DB	DF	DT	37	34.5	65	67.5	1	0.6
<hr/>														
19.5	17.7	1 990	1 810	10 000	13 000	DB	DF	DT	39.5	39.5	50.5	52.5	0.6	0.3
28.5	25.1	2 900	2 560	9 400	13 000	DB	DF	DT	40.5	40.5	56.5	57.5	1	0.6
48.5	40.0	4 900	4 100	8 600	11 000	DB	DF	DT	42	39.5	65	67.5	1	0.6
44.0	36.5	4 500	3 750	7 500	10 000	DB	DF	DT	42	39.5	65	67.5	1	0.6
65.0	52.5	6 600	5 350	7 800	10 000	DB	DF	DT	43.5	40.5	71.5	74.5	1.5	1
59.5	48.5	6 100	4 950	6 800	9 000	DB	DF	DT	43.5	40.5	71.5	74.5	1.5	1
<hr/>														
20.6	20.4	2 100	2 080	9 000	12 000	DB	DF	DT	44.5	44.5	57.5	59.5	0.6	0.3
30.5	29.2	3 100	2 970	8 300	11 000	DB	DF	DT	45.5	45.5	62.5	63.5	1	0.6
57.5	50.5	5 850	5 150	7 700	10 000	DB	DF	DT	47	44.5	73.0	75.5	1	0.6
52.0	46.0	5 300	4 700	6 700	8 900	DB	DF	DT	47	44.5	73	75.5	1	0.6
79.5	66.0	8 100	6 700	6 900	9 200	DB	DF	DT	48.5	45.5	81.5	84.5	1.5	1
73.0	60.5	7 400	6 200	6 000	8 000	DB	DF	DT	48.5	45.5	81.5	84.5	1.5	1
<hr/>														
25.5	25.7	2 600	2 620	8 100	11 000	DB	DF	DT	49.5	49.5	63.5	65.5	0.6	0.3
36.0	35.5	3 700	3 600	7 500	10 000	DB	DF	DT	50.5	50.5	69.5	70.5	1	0.6
64.5	57.5	6 550	5 850	6 900	9 200	DB	DF	DT	52	49.5	78	80.5	1	0.6
58.5	52.5	5 950	5 350	6 000	8 000	DB	DF	DT	52	49.5	78	80.5	1	0.6
103	88.0	10 500	8 950	6 200	8 200	DB	DF	DT	53.5	50.5	91.5	94.5	1.5	1
95.0	80.5	9 650	8 250	5 400	7 200	DB	DF	DT	53.5	50.5	91.5	94.5	1.5	1
<hr/>														
27.0	28.9	2 750	2 950	7 300	9 800	DB	DF	DT	54.5	54.5	67.5	69.5	0.6	0.3
38.5	40.0	3 900	4 100	6 800	9 100	DB	DF	DT	55.5	55.5	74.5	75.5	1	0.6
67.0	63.0	6 850	6 400	6 300	8 300	DB	DF	DT	57	54.5	83	85.5	1	0.6
60.5	57.0	6 200	5 850	5 500	7 300	DB	DF	DT	57	54.5	83	85.5	1	0.6
121	105	12 300	10 700	5 600	7 500	DB	DF	DT	60	55.5	100	104.5	2	1
111	96.0	11 300	9 850	4 900	6 500	DB	DF	DT	60	55.5	100	104.5	2	1
<hr/>														
28.1	32.0	2 870	3 300	6 700	8 900	DB	DF	DT	60.5	60.5	74.5	75.5	1	0.6
50.5	52.5	5 150	5 350	6 300	8 400	DB	DF	DT	62	62	83	85.5	1	0.6
83.0	79.0	8 450	8 050	5 700	7 600	DB	DF	DT	63.5	60.5	91.5	94.5	1.5	1
75.0	72.0	7 650	7 350	5 000	6 600	DB	DF	DT	63.5	60.5	91.5	94.5	1.5	1
139	123	14 200	12 600	5 100	6 800	DB	DF	DT	65	60.5	110	114.5	2	1
128	113	13 000	11 600	4 500	5 900	DB	DF	DT	65	60.5	110	114.5	2	1

Note: For bearing series 79 and 70, inner rings are constructed with groove abutments on both sides. Therefore, the inner ring chamfer dimension r_1 is identical to dimension r_a . Furthermore, the radius r_{1a} of the shaft corner roundness is likewise identical to r_a .

Single and Duplex Angular Contact Ball Bearings

MBR

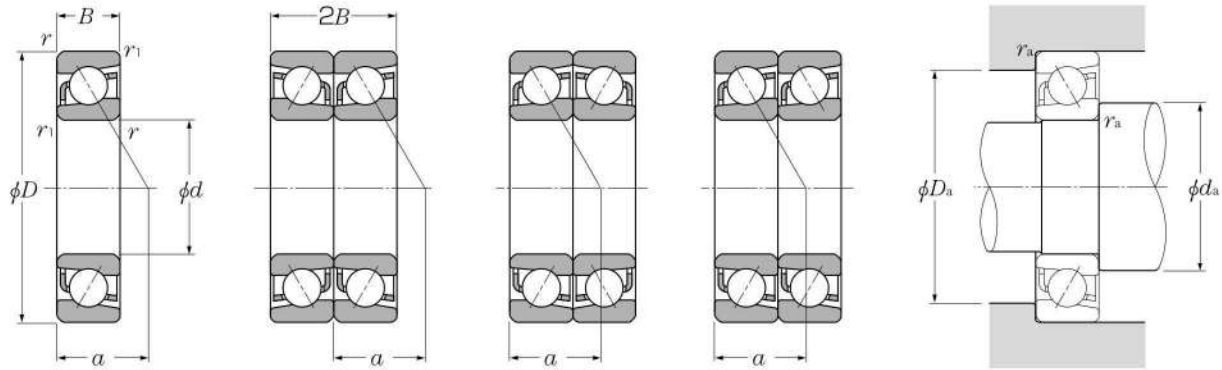

Single

Back-to-back arrangement (DB)

Face-to-face arrangement (DF)

Tandem arrangement (DT)

d 60 ~ 85mm

d	Boundary dimensions					Basic load ratings				Limiting speeds ¹⁾		Bearing numbers ²⁾	Load center mm a	Mass kg single (approx.)
	D	B	2B	r _{s min} ³⁾	r _{s min} ³⁾	dynamic kN C _r	static C _{or}	dynamic kgf C _r	static C _{or}	grease	oil			
60	85	13	26	1	0.6	18.1	17.4	1 840	1 780	7 800	10 000	7912	27.5	0.23
	95	18	36	1.1	0.6	32.0	28.1	3 250	2 860	7 200	9 600	7012	31.5	0.478
	110	22	44	1.5	1	61.5	49.0	6 300	5 000	6 600	8 800	7212	36	0.765
	110	22	44	1.5	1	56.0	44.5	5 700	4 550	5 700	7 600	7212B	47.5	0.78
	130	31	62	2.1	1.1	98.0	71.5	10 000	7 300	5 900	7 900	7312	43	1.74
	130	31	62	2.1	1.1	90.0	66.0	9 200	6 700	5 100	6 800	7312B	56	1.77
65	90	13	26	1	0.6	18.3	18.0	1 860	1 840	7 200	9 600	7913	29	0.245
	100	18	36	1.1	0.6	33.5	31.5	3 450	3 200	6 700	9 000	7013	33	0.509
	120	23	46	1.5	1	70.5	58.0	7 150	5 900	6 100	8 100	7213	38	0.962
	120	23	46	1.5	1	63.5	52.5	6 500	5 350	5 200	7 000	7213B	50.5	0.981
	140	33	66	2.1	1.1	111	82.0	11 300	8 350	5 500	7 300	7313	46	2.11
	140	33	66	2.1	1.1	102	75.0	10 400	7 700	4 700	6 300	7313B	59.5	2.15
70	100	16	32	1	0.6	26.2	26.2	2 670	2 670	6 700	9 000	7914	32.5	0.397
	110	20	40	1.1	0.6	42.5	39.5	4 350	4 000	6 200	8 300	7014	36	0.705
	125	24	48	1.5	1	76.5	63.5	7 800	6 500	5 700	7 600	7214	40	1.09
	125	24	48	1.5	1	69.0	58.0	7 050	5 900	4 900	6 500	7214B	53	1.11
	150	35	70	2.1	1.1	125	93.5	12 700	9 550	5 100	6 800	7314	49.5	2.56
	150	35	70	2.1	1.1	114	86	11 700	8 800	4 400	5 800	7314B	63.5	2.61
75	105	16	32	1	0.6	26.50	27.1	2 710	2 760	6 300	8 400	7915	34	0.42
	115	20	40	1.1	0.6	43.50	41.5	4 450	4 250	5 800	7 800	7015	37.5	0.745
	130	25	50	1.5	1	79.0	68.5	8 050	7 000	5 300	7 100	7215	42.5	1.17
	130	25	50	1.5	1	71.5	62.0	7 300	6 350	4 500	6 000	7215B	56	1.19
	160	37	74	2.1	1.1	136	106	13 800	10 800	4 800	6 300	7315	52.5	3.07
	160	37	74	2.1	1.1	125	97.5	12 700	9 900	4 100	5 400	7315B	68	3.13
80	110	16	32	1	0.6	26.9	28.0	2 740	2 860	5 900	7 800	7916	35.5	0.444
	125	22	44	1.1	0.6	53.5	50.5	5 450	5 150	5 500	7 300	7016	40.5	0.994
	140	26	52	2	1	89.0	76.0	9 100	7 750	5 000	6 600	7216	45	1.39
	140	26	52	2	1	80.5	69.5	8 200	7 050	4 300	5 700	7216B	59	1.42
	170	39	78	2.1	1.1	147	119	15 000	12 100	4 500	5 900	7316	55.5	3.65
	170	39	78	2.1	1.1	135	109	13 800	11 100	3 800	5 100	7316B	72	3.72
85	120	18	36	1.1	0.6	36.0	38.0	3 700	3 850	5 500	7 400	7917	38.5	0.628
	130	22	44	1.1	0.6	54.5	53.5	5 600	5 450	5 100	6 900	7017	42	1.04
	150	28	56	2	1	99.5	88.5	10 100	9 050	4 700	6 200	7217	48	1.78
	150	28	56	2	1	90.0	80.5	9 150	8 200	4 000	5 300	7217B	63.5	1.82

1) This value achieved with machined cages; when pressed cages are used, 80% of this value is acceptable.

2) Bearing numbers appended with the code "B" have a contact angle of 40°; bearings with this code have a contact angle of 30°.

3) Smallest allowable dimension for chamfer dimension r or r₁.

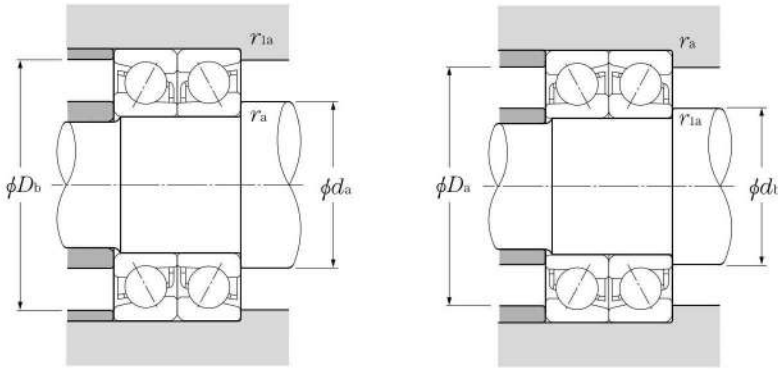

Dynamic equivalent radial load

$$P_r = XF_r + YF_a$$

Contact angle	e	Single, DT				DB, DF			
		$F_a/F_r \leq e$		$F_a/F_r > e$		$F_a/F_r \leq e$		$F_a/F_r > e$	
		X	Y	X	Y	X	Y	X	Y
30°	0.80	1	0	0.39	0.76	1	0.78	0.63	1.24
40°	1.14	1	0	0.35	0.57	1	0.55	0.57	0.93

Static equivalent radial load

$$P_{or} = X_o F_r + Y_o F_a$$

Contact angle	Single, DT		DB, DF	
	X_o	Y_o	X_o	Y_o
30°	0.5	0.33	1	0.66
40°	0.5	0.26	1	0.52

For single and DT arrangement,
When $P_{or} < F_r$ use $P_{or} = F_r$

Basic load ratings				Limiting speeds ¹⁾		Bearing numbers ²⁾			Abutment and fillet dimensions					
dynamic (duplex) kN	static kN	dynamic (duplex) kgf	static kgf	(duplex) min ⁻¹		DB	DF	DT	mm					
C_r	C_{or}	C_r	C_{or}	grease	oil				d_a min	d_b min	D_a max	D_b max	r_{as} max	r_{ias} max
29.3	35.0	2 990	3 550	6 200	8 300	DB	DF	DT	65.5	65.5	79.5	80.5	1	0.6
52.0	56.0	5 300	5 700	5 800	7 700	DB	DF	DT	67	67	88	90.5	1	0.6
100	98.0	10 200	10 000	5 300	7 000	DB	DF	DT	68.5	65.5	101.5	104.5	1.5	1
91.0	89.0	9 250	9 100	4 600	6 100	DB	DF	DT	68.5	65.5	101.5	104.5	1.5	1
159	143	16 200	14 600	4 700	6 300	DB	DF	DT	72	67	118	123	2	1
146	132	14 900	13 400	4 100	5 500	DB	DF	DT	72	67	118	123	2	1
29.7	36.0	3 050	3 700	5 700	7 600	DB	DF	DT	70.5	70.5	84.5	85.5	1	0.6
55.0	62.5	5 600	6 400	5 400	7 100	DB	DF	DT	72	72	93	95.5	1	0.6
114	116	11 600	11 800	4 900	6 500	DB	DF	DT	73.5	70.5	111.5	114.5	1.5	1
103	105	10 500	10 700	4 200	5 600	DB	DF	DT	73.5	70.5	111.5	114.5	1.5	1
180	164	18 400	16 700	4 400	5 800	DB	DF	DT	77	72	128	133	2	1
166	151	16 900	15 400	3 800	5 100	DB	DF	DT	77	72	128	133	2	1
42.5	52.5	4 350	5 350	5 300	7 100	DB	DF	DT	75.5	75.5	94.5	95.5	1	0.6
69.5	78.5	7 050	8 050	5 000	6 600	DB	DF	DT	77	77	103	105.5	1	0.6
124	127	12 600	13 000	4 500	6 000	DB	DF	DT	78.5	75.5	116.5	119.5	1.5	1
112	116	11 500	11 800	3 900	5 200	DB	DF	DT	78.5	75.5	116.5	119.5	1.5	1
203	187	20 700	19 100	4 100	5 400	DB	DF	DT	82	77	138	143	2	1
186	172	19 000	17 600	3 500	4 700	DB	DF	DT	82	77	138	143	2	1
43.0	54.0	4 400	5 500	5 000	6 700	DB	DF	DT	80.5	80.5	99.5	100.5	1	0.6
71.0	83.5	7 250	8 500	4 600	6 200	DB	DF	DT	82	82	108	110.5	1	0.6
128	137	13 100	14 000	4 200	5 600	DB	DF	DT	83.5	80.5	121.5	124.5	1.5	1
116	124	11 800	12 700	3 700	4 900	DB	DF	DT	83.5	80.5	121.5	124.5	1.5	1
221	212	22 500	21 600	3 800	5 000	DB	DF	DT	87	82	148	153	2	1
202	195	20 600	19 800	3 300	4 400	DB	DF	DT	87	82	148	153	2	1
43.5	56.0	4 450	5 700	4 700	6 200	DB	DF	DT	85.5	85.5	104.5	105.5	1	0.6
86.5	101	8 850	10 300	4 400	5 800	DB	DF	DT	87	87	118	120.5	1	0.6
145	152	14 700	15 500	3 900	5 300	DB	DF	DT	90	85.5	130	134.5	2	1
131	139	13 300	14 100	3 400	4 600	DB	DF	DT	90	85.5	130	134.5	2	1
239	238	24 400	24 200	3 500	4 700	DB	DF	DT	92	87	158	163	2	1
219	218	22 300	22 300	3 100	4 100	DB	DF	DT	92	87	158	163	2	1
59.0	76.0	6 000	7 750	4 400	5 900	DB	DF	DT	92	92	113	115.5	1	0.6
89.0	107	9 050	10 900	4 100	5 500	DB	DF	DT	92	92	123	125.5	1	0.6
162	177	16 500	18 100	3 700	5 000	DB	DF	DT	95	90.5	140	144.5	2	1
146	161	14 900	16 400	3 200	4 300	DB	DF	DT	95	90.5	140	144.5	2	1

Note: For bearing series 79 and 70, inner rings are constructed with groove abutments on both sides. Therefore, the inner ring chamfer dimension r_i is identical to dimension r_{1a} . Furthermore, the radius r_{1a} of the shaft corner roundness is likewise identical to r_{1a} .

Single and Duplex Angular Contact Ball Bearings

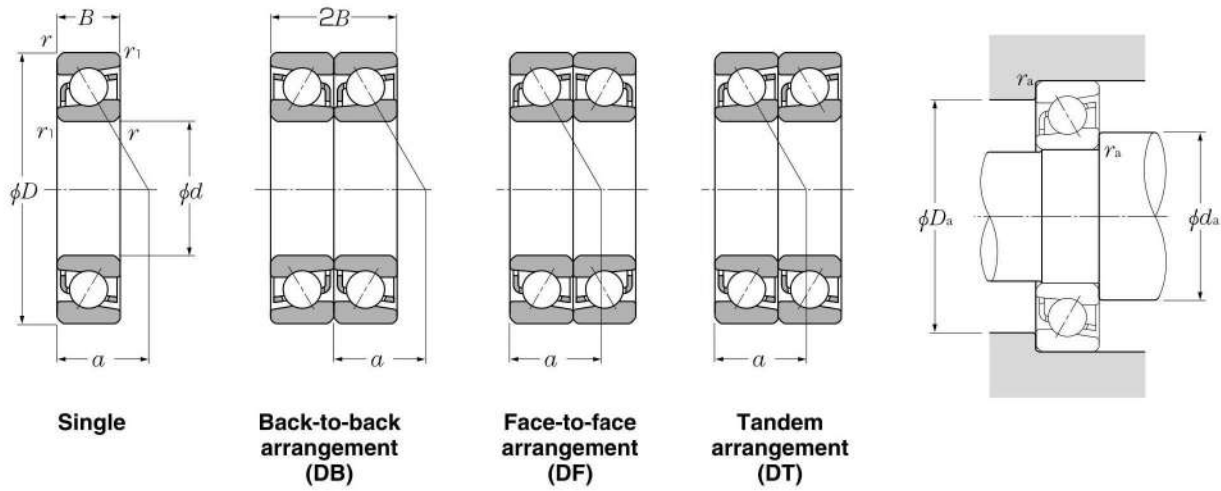

d 85 ~ 120mm

d	Boundary dimensions					Basic load ratings				Limiting speeds ¹⁾		Bearing numbers ²⁾	Load center mm a	Mass kg single (approx.)
	D	B	2B	r _{s.min} ³⁾	r _{ls.min} ³⁾	dynamic kN C _r	static kN C _{or}	dynamic kgf C _r	static kgf C _{or}	grease	oil			
85	180	41	82	3	1.1	159	133	16 200	13 500	4 200	5 600	7317	59	4.34
	180	41	82	3	1.1	146	122	14 800	12 400	3 600	4 800	7317B	76	4.43
90	125	18	36	1.1	0.6	36.0	38.0	3 650	3 850	5 200	7 000	7918	40	0.658
	140	24	48	1.5	1	65.0	63.5	6 650	6 450	4 900	6 500	7018	45	1.35
	160	30	60	2.0	1	118	103	12 000	10 500	4 400	5 900	7218	51	2.18
	160	30	60	2.0	1	107	94.0	10 900	9 550	3 800	5 000	7218B	67.5	2.22
	190	43	86	3.0	1.1	171	147	17 400	15 000	4 000	5 300	7318	62	5.06
190	43	86	3.0	1.1	156	135	15 900	13 800	3 400	4 500	7318B	80.5	5.16	
95	130	18	36	1.1	0.6	37.0	40.5	3 800	4 150	5 000	6 600	7919	41.5	0.688
	145	24	48	1.5	1	67.0	67.0	6 800	6 800	4 600	6 100	7019	46.5	1.41
	170	32	64	2.1	1.1	133	118	13 600	12 000	4 100	5 500	7219	54.5	2.67
	170	32	64	2.1	1.1	121	107	12 300	11 000	3 500	4 700	7219B	71.5	2.72
	200	45	90	3	1.1	183	162	18 600	16 600	3 700	5 000	7319	65	5.89
200	45	90	3	1.1	167	149	17 100	15 200	3 200	4 200	7319B	84.5	6	
100	140	20	40	1.1	0.6	48.0	52.5	4 900	5 350	4 700	6 200	7920	44.5	0.934
	150	24	48	1.5	1	68.5	70.5	6 950	7 200	4 400	5 800	7020	48	1.47
	180	34	68	2.1	1.1	144	126	14 700	12 800	3 900	5 200	7220	57.5	3.2
	180	34	68	2.1	1.1	130	114	13 300	11 700	3 400	4 500	7220B	76	3.26
	215	47	94	3	1.1	207	193	21 100	19 700	3 500	4 700	7320	69	7.18
215	47	94	3	1.1	190	178	19 400	18 100	3 000	4 000	7320B	89.5	7.32	
105	145	20	40	1.1	0.6	48.5	54.5	4 950	5 550	4 400	5 900	7921	46	0.972
	160	26	52	2	1	80.0	81.5	8 150	8 350	4 100	5 500	7021	51.5	1.86
	190	36	72	2.1	1.1	157	142	16 000	14 400	3 700	5 000	7221	60.5	3.79
	190	36	72	2.1	1.1	142	129	14 500	13 100	3 200	4 300	7221B	80	3.87
	225	49	98	3	1.1	220	210	22 400	21 500	3 400	4 500	7321	72	8.2
225	49	98	3	1.1	202	194	20 600	19 700	2 900	3 800	7321B	93.5	8.36	
110	150	20	40	1.1	0.6	49.5	56.0	5 050	5 700	4 200	5 700	7922	47.5	1.01
	170	28	56	2	1	92.0	93.0	9 350	9 450	3 900	5 300	7022	54.5	2.3
	200	38	76	2.1	1.1	170	158	17 300	16 100	3 500	4 700	7222	64	4.45
	200	38	76	2.1	1.1	154	144	15 700	14 700	3 000	4 000	7222B	84	4.54
	240	50	100	3	1.1	246	246	25 100	25 100	3 200	4 300	7322	76	9.6
240	50	100	3	1.1	226	226	23 000	23 100	2 700	3 700	7322B	99	9.8	
120	165	22	44	1.1	0.6	61.0	69.5	6 200	7 100	3 900	5 200	7924	52	1.66

1) This value achieved with machined cages; when pressed cages are used, 80% of this value is acceptable.
 2) Bearing numbers appended with the code "B" have a contact angle of 40°; bearings with this code have a contact angle of 30°.
 3) Smallest allowable dimension for chamfer dimension r or r₁.

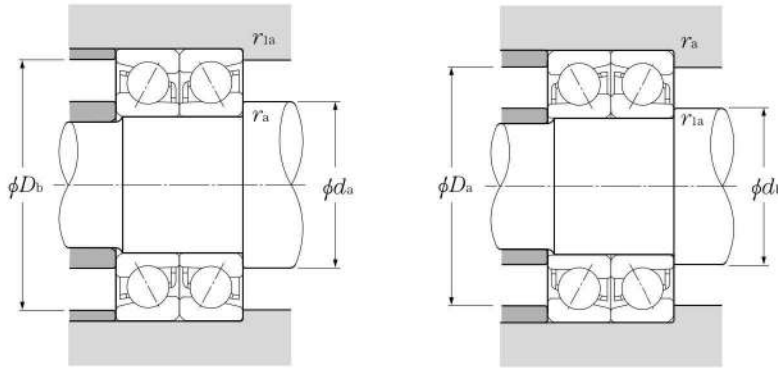

Dynamic equivalent radial load

$$P_r = X F_r + Y F_a$$

Contact angle	e	Single, DT				DB, DF			
		$F_a/F_r \leq e$		$F_a/F_r > e$		$F_a/F_r \leq e$		$F_a/F_r > e$	
		X	Y	X	Y	X	Y	X	Y
30°	0.80	1	0	0.39	0.76	1	0.78	0.63	1.24
40°	1.14	1	0	0.35	0.57	1	0.55	0.57	0.93

Static equivalent radial load

$$P_{or} = X_o F_r + Y_o F_a$$

Contact angle	Single, DT		DB, DF	
	X_o	Y_o	X_o	Y_o
30°	0.5	0.33	1	0.66
40°	0.5	0.26	1	0.52

For single and DT arrangement,

When $P_{or} < F_r$ use $P_{or} = F_r$

Basic load ratings				Limiting speeds ¹⁾		Bearing numbers ²⁾			Abutment and fillet dimensions					
dynamic (duplex) kN	static kN	dynamic (duplex) kgf	static (duplex) kgf	(duplex) min ⁻¹		DB	DF	DT	mm					
C_r	C_{or}	C_r	C_{or}	grease	oil				d_a min	d_b min	D_a max	D_b max	r_{1a} max	r_{1as} max
258	265	26 300	27 000	3 300	4 500	DB	DF	DT	99	92	166	173	2.5	1
236	244	24 100	24 900	2 900	3 900	DB	DF	DT	99	92	166	173	2.5	1
58.0	75.5	5 900	7 700	4 200	5 500	DB	DF	DT	97	97	118	120.5	1	0.6
106	127	10 800	12 900	3 900	5 200	DB	DF	DT	98.5	98.5	131.5	134.5	1.5	1
191	206	19 500	21 000	3 500	4 700	DB	DF	DT	100	95.5	150	154.5	2	1
173	188	17 700	19 100	3 100	4 100	DB	DF	DT	100	95.5	150	154.5	2	1
277	294	28 300	30 000	3 200	4 200	DB	DF	DT	104	97	176	183	2.5	1
254	270	25 900	27 600	2 700	3 700	DB	DF	DT	104	97	176	183	2.5	1
60.5	81.5	6 150	8 300	3 900	5 300	DB	DF	DT	102	102	123	125.5	1	0.6
109	134	11 100	13 600	3 700	4 900	DB	DF	DT	103.5	103.5	136.5	139.5	1.5	1
217	236	22 100	24 100	3 300	4 400	DB	DF	DT	107	102	158	163	2	1
196	215	20 000	21 900	2 900	3 800	DB	DF	DT	107	102	158	163	2	1
297	325	30 500	33 000	3 000	3 900	DB	DF	DT	109	102	186	193	2.5	1
272	298	27 700	30 500	2 600	3 400	DB	DF	DT	109	102	186	193	2.5	1
78.0	105	7 950	10 700	3 700	5 000	DB	DF	DT	107	107	133	135.5	1	0.6
111	141	11 300	14 400	3 500	4 600	DB	DF	DT	108.5	108.5	141.5	144.5	1.5	1
233	251	23 800	25 600	3 100	4 200	DB	DF	DT	112	107	168	173	2	1
212	229	21 600	23 300	2 700	3 600	DB	DF	DT	112	107	168	173	2	1
335	385	34 500	39 500	2 800	3 700	DB	DF	DT	114	107	201	208	2.5	1
310	355	31 500	36 000	2 400	3 300	DB	DF	DT	114	107	201	208	2.5	1
79.0	109	8 050	11 100	3 500	4 700	DB	DF	DT	112	112	138	140.5	1	0.6
130	163	13 300	16 700	3 300	4 400	DB	DF	DT	115	115	150	154.5	2	1
254	283	25 900	28 900	3 000	4 000	DB	DF	DT	117	112	178	183	2	1
231	258	23 500	26 300	2 600	3 500	DB	DF	DT	117	112	178	183	2	1
355	420	36 500	43 000	2 700	3 600	DB	DF	DT	119	112	211	218	2.5	1
330	385	33 500	39 500	2 300	3 100	DB	DF	DT	119	112	211	218	2.5	1
80.0	112	8 150	11 400	3 400	4 500	DB	DF	DT	117	117	143	145.5	1	0.6
149	186	15 200	18 900	3 100	4 200	DB	DF	DT	120	120	160	164.5	2	1
276	315	28 100	32 500	2 800	3 800	DB	DF	DT	122	117	188	193	2	1
250	289	25 500	29 400	2 500	3 300	DB	DF	DT	122	117	188	193	2	1
400	490	41 000	50 000	2 600	3 400	DB	DF	DT	124	117	226	233	2.5	1
365	455	37 500	46 000	2 200	3 000	DB	DF	DT	124	117	226	233	2.5	1
99.0	139	10 100	14 200	3 100	4 100	DB	DF	DT	127	127	158	160.5	1	0.6

Note: For bearing series 79 and 70, inner rings are constructed with groove abutments on both sides. Therefore, the inner ring chamfer dimension r_1 is identical to dimension r_{1a} . Furthermore, the radius r_{1a} of the shaft corner roundness is likewise identical to r_{1a} .

Single and Duplex Angular Contact Ball Bearings

MBR

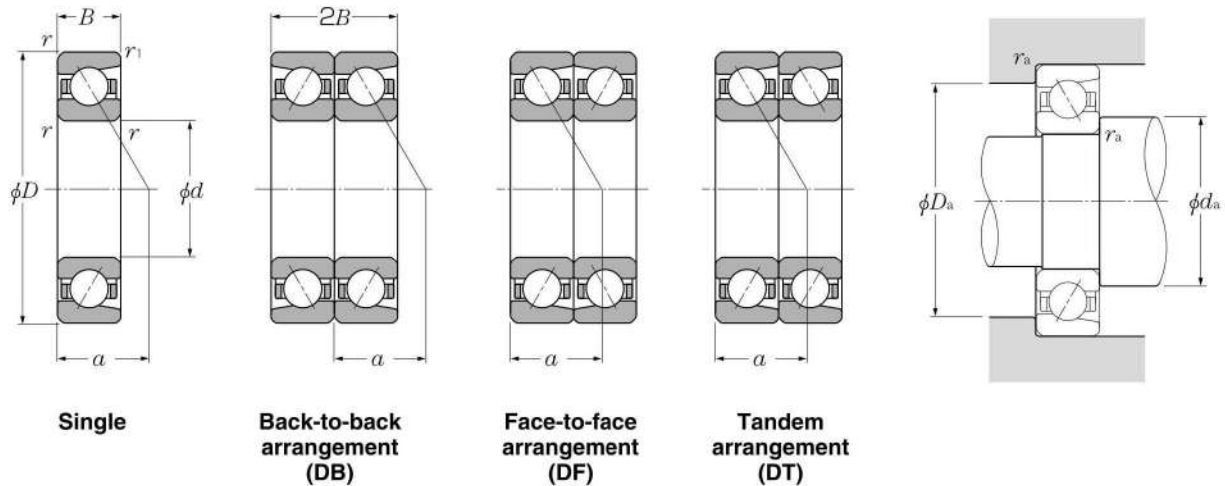

d 120 ~ 170mm

d	Boundary dimensions					Basic load ratings				Limiting speeds		Bearing numbers	Load center mm a	Mass kg single (approx.)
	D	B	2B	$r_{s \text{ min}^2}$	$r_{is \text{ min}^2}$	dynamic	static	dynamic	static	grease	oil			
	mm	mm	mm	mm	mm	kN	kN	kgf	kgf	min ⁻¹	min ⁻¹			
120	180	28	56	2	1	93.5	98.5	9 550	10 000	3 600	4 800	7024	57.5	2.47
	215	40	80	2.1	1.1	183	177	18 600	18 100	3 200	4 300	7224	68.5	6.26
	215	40	80	2.1	1.1	165	162	16 900	16 500	2 800	3 700	7224B	90.5	6.26
	260	55	110	3	1.1	246	252	25 100	25 700	2 900	3 900	7324	82.5	14.7
	260	55	110	3	1.1	225	231	23 000	23 600	2 500	3 300	7324B	107	14.7
130	180	24	48	1.5	1	75.0	87.5	7 650	8 900	3 600	4 700	7926	56.5	1.82
	200	33	66	2	1	117	125	12 000	12 800	3 300	4 400	7026	64	3.73
	230	40	80	3	1.1	196	198	20 000	20 200	3 000	4 000	7226	72	7.15
	230	40	80	3	1.1	177	180	18 100	18 300	2 500	3 400	7226B	95.5	7.15
	280	58	116	4	1.5	273	293	27 900	29 800	2 700	3 600	7326	88	17.6
280	58	116	4	1.5	250	268	25 500	27 400	2 300	3 100	7326B	115	17.6	
140	190	24	48	1.5	1	75.5	90.0	7 700	9 150	3 300	4 400	7928	59.5	1.94
	210	33	66	2	1	120	133	12 200	13 500	3 100	4 100	7028	67	3.96
	250	42	84	3	1.1	203	215	20 700	21 900	2 700	3 600	7228	77.5	8.78
	250	42	84	3	1.1	183	195	18 700	19 900	2 300	3 100	7228B	103	8.78
	300	62	124	4	1.5	300	335	30 500	34 500	2 500	3 300	7328	94.5	21.5
300	62	124	4	1.5	275	310	28 100	31 500	2 100	2 800	7328B	123	21.5	
150	210	28	56	2	1	97.5	117	9 900	11 900	3 100	4 100	7930	66	2.96
	225	35	70	2.1	1.1	137	154	14 000	15 700	2 800	3 800	7030	71.5	4.82
	270	45	90	3	1.1	232	259	23 700	26 400	2 500	3 400	7230	83	11
	270	45	90	3	1.1	210	235	21 400	24 000	2 200	2 900	7230B	111	11
	320	65	130	4	1.5	330	380	33 500	39 000	2 300	3 100	7330	100	25.1
320	65	130	4	1.5	300	350	30 500	36 000	2 000	2 600	7330B	131	25.1	
160	220	28	56	2	1	98.5	121	10 000	12 300	2 800	3 800	7932	69	3.13
	240	38	76	2.1	1.1	155	176	15 800	18 000	2 700	3 600	7032	77	5.96
	290	48	96	3	1.1	263	305	26 800	31 500	2 400	3 200	7232	89	13.7
	290	48	96	3	1.1	238	279	24 200	28 400	2 000	2 700	7232B	118	13.7
	340	68	136	4	1.5	345	420	35 500	43 000	2 100	2 800	7332	106	29.8
340	68	136	4	1.5	315	385	32 000	39 500	1 800	2 400	7332B	139	29.8	
170	230	28	56	2	1	102	129	10 400	13 100	2 700	3 600	7934	71.5	3.29
	260	42	84	2.1	1.1	186	214	18 900	21 900	2 500	3 300	7034	83	7.96
	310	52	104	4	1.5	295	360	30 000	36 500	2 200	3 000	7234	95.5	17
	310	52	104	4	1.5	266	325	27 200	33 000	1 900	2 500	7234B	127	17
	360	72	144	4	1.5	390	485	39 500	49 500	2 000	2 700	7334	113	35.3

1) Bearing numbers appended with the code "B" have a contact angle of 40°; bearings with this code have a contact angle of 30°.
 2) Smallest allowable dimension for chamfer dimension r or r_1 .

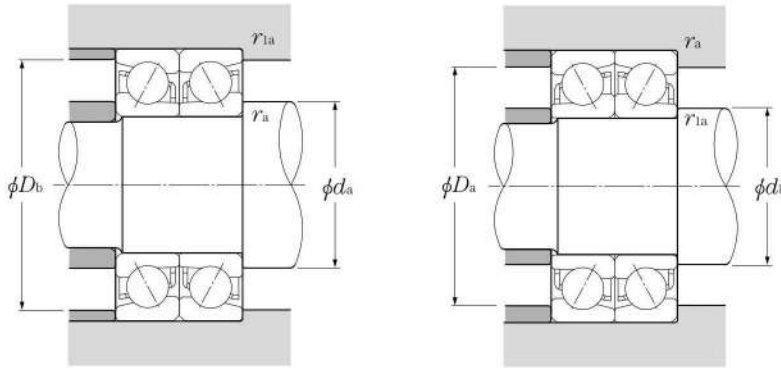

Dynamic equivalent radial load

$$P_r = X F_r + Y F_a$$

Contact angle	e	Single, DT				DB, DF			
		$F_a/F_r \leq e$		$F_a/F_r > e$		$F_a/F_r \leq e$		$F_a/F_r > e$	
		X	Y	X	Y	X	Y	X	Y
30°	0.80	1	0	0.39	0.76	1	0.78	0.63	1.24
40°	1.14	1	0	0.35	0.57	1	0.55	0.57	0.93

Static equivalent radial load

$$P_{or} = X_o F_r + Y_o F_a$$

Contact angle	Single, DT		DB, DF	
	X_o	Y_o	X_o	Y_o
30°	0.5	0.33	1	0.66
40°	0.5	0.26	1	0.52

For single and DT arrangement,

When $P_{or} < F_r$ use $P_{or} = F_r$

Basic load ratings				Limiting speeds		Bearing numbers ¹⁾			Abutment and fillet dimensions				
dynamic (duplex) kN	static C_{or}	dynamic (duplex) kgf	static C_{or}	(duplex) min ⁻¹		DB	DF	DT	mm				
C_r	C_{or}	C_r	C_{or}	grease	oil				d_s min	D_s max	D_b max	r_{as} max	r_{is} max
152	197	15 500	20 100	2 900	3 800	DB	DF	DT	130	170	174.5	2	1
297	355	30 500	36 000	2 600	3 400	DB	DF	DT	132	203	208	2	1
269	325	27 400	33 000	2 300	3 000	DB	DF	DT	132	203	208	2	1
400	505	41 000	51 500	2 300	3 100	DB	DF	DT	134	246	253	2.5	1
365	460	37 500	47 000	2 000	2 700	DB	DF	DT	134	246	253	2.5	1
121	175	12 400	17 800	2 800	3 800	DB	DF	DT	138.5	171.5	174.5	1.5	1
191	251	19 400	25 600	2 600	3 500	DB	DF	DT	140	190	194.5	2	1
320	395	32 500	40 500	2 400	3 100	DB	DF	DT	144	216	223	2.5	1
288	360	29 400	36 500	2 100	2 700	DB	DF	DT	144	216	223	2.5	1
445	585	45 500	59 500	2 100	2 800	DB	DF	DT	148	262	271.5	3	1.5
405	535	41 500	54 500	1 900	2 500	DB	DF	DT	148	262	271.5	3	1.5
123	180	12 500	18 300	2 600	3 500	DB	DF	DT	148.5	181.5	184.5	1.5	1
194	265	19 800	27 000	2 400	3 300	DB	DF	DT	150	200	204.5	2	1
330	430	33 500	44 000	2 200	2 900	DB	DF	DT	154	236	243	2.5	1
297	390	30 500	40 000	1 900	2 500	DB	DF	DT	154	236	243	2.5	1
490	670	50 000	68 500	2 000	2 600	DB	DF	DT	158	282	291.5	3	1.5
445	615	45 500	63 000	1 700	2 300	DB	DF	DT	158	282	291.5	3	1.5
158	234	16 100	23 900	2 400	3 300	DB	DF	DT	160	200	204.5	2	1
222	305	22 700	31 500	2 300	3 000	DB	DF	DT	162	213	218	2	1
375	515	38 500	53 000	2 000	2 700	DB	DF	DT	164	256	263	2.5	1
340	470	34 500	48 000	1 800	2 400	DB	DF	DT	164	256	263	2.5	1
535	765	54 500	78 000	1 800	2 400	DB	DF	DT	168	302	311.5	3	1.5
490	700	50 000	71 500	1 600	2 100	DB	DF	DT	168	302	311.5	3	1.5
160	241	16 300	24 600	2 300	3 000	DB	DF	DT	170	210	214.5	2	1
252	355	25 700	36 000	2 100	2 800	DB	DF	DT	172	228	233	2	1
425	615	43 500	62 500	1 900	2 500	DB	DF	DT	174	276	283	2.5	1
385	555	39 500	57 000	1 600	2 200	DB	DF	DT	174	276	283	2.5	1
565	845	57 500	86 000	1 700	2 300	DB	DF	DT	178	322	331.5	3	1.5
515	770	52 500	79 000	1 500	2 000	DB	DF	DT	178	322	331.5	3	1.5
165	257	16 900	26 200	2 100	2 800	DB	DF	DT	180	220	224.5	2	1
300	430	31 000	43 500	2 000	2 600	DB	DF	DT	182	248	253	2	1
480	715	49 000	73 000	1 800	2 400	DB	DF	DT	188	292	301.5	3	1.5
435	650	44 000	66 500	1 500	2 100	DB	DF	DT	188	292	301.5	3	1.5
630	970	64 500	99 000	1 600	2 100	DB	DF	DT	188	342	351.5	3	1.5

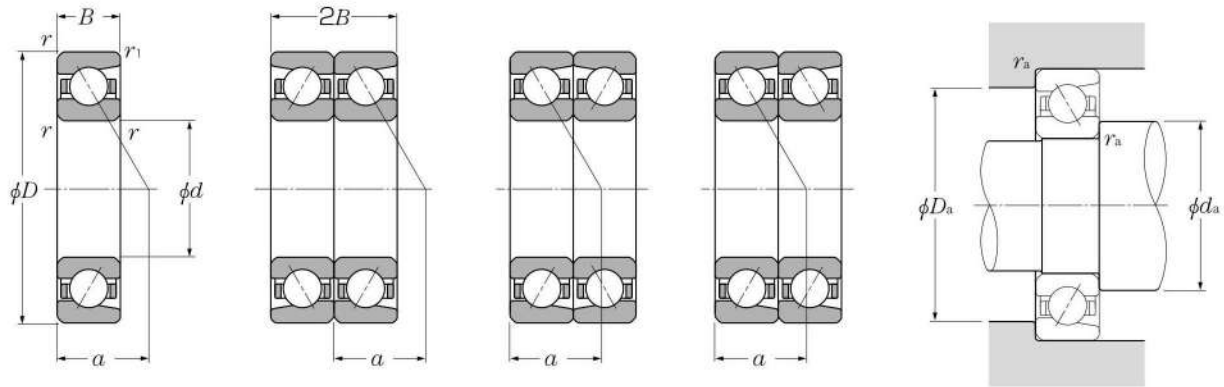

Single

Back-to-back arrangement (DB)

Face-to-face arrangement (DF)

Tandem arrangement (DT)

d 170 ~ 300mm

d	Boundary dimensions					Basic load ratings				Limiting speeds		Bearing numbers	Load center mm a	Mass kg single (approx.)
	D	B	2B	$r_{s \min}^{(2)}$	$r_{ls \min}^{(2)}$	dynamic kN C_r	static kN C_{or}	dynamic kgf C_r	static kgf C_{or}	grease	oil			
170	360	72	144	4	1.5	355	445	36 000	45 500	1 700	2 300	7334B	147	35.3
180	250	33	66	2	1	131	163	13 400	16 600	2 500	3 300	7936	78.5	4.87
	280	46	92	2.1	1.1	219	266	22 300	27 100	2 300	3 100	7036	89.5	10.4
	320	52	104	4	1.5	305	385	31 000	39 000	2 100	2 800	7236	98	17.7
	320	52	104	4	1.5	276	350	28 100	35 500	1 800	2 400	7236B	131	17.7
	380	75	150	4	1.5	410	535	41 500	54 500	1 900	2 500	7336	118	40.9
	380	75	150	4	1.5	375	490	38 000	50 000	1 600	2 100	7336B	155	40.9
190	260	33	66	2	1	133	169	13 500	17 200	2 400	3 200	7938	81.5	5.1
	290	46	92	2.1	1.1	224	280	22 800	28 600	2 200	2 900	7038	92.5	10.8
	340	55	110	4	1.5	305	390	31 000	39 500	2 000	2 600	7238	104	21.3
	340	55	110	4	1.5	273	355	27 800	36 000	1 700	2 200	7238B	139	21.3
	400	78	156	5	2	430	585	44 000	59 500	1 800	2 300	7338	124	47
	400	78	156	5	2	390	535	40 000	54 500	1 500	2 000	7338B	163	47
200	280	38	76	2.1	1.1	185	231	18 900	23 600	2 200	3 000	7940	88.5	7.15
	310	51	102	2.1	1.1	252	325	25 700	33 000	2 100	2 800	7040	99	14
	360	58	116	4	1.5	335	450	34 500	46 000	1 900	2 500	7240	110	25.3
	360	58	116	4	1.5	305	410	31 000	41 500	1 600	2 100	7240B	146	25.3
	420	80	160	5	2	450	605	46 000	62 000	1 700	2 200	7340	130	53.1
	420	80	160	5	2	410	555	42 000	56 500	1 400	1 900	7340B	170	53.1
220	300	38	76	2.1	1.1	187	239	19 000	24 300	2 000	2 700	7944	94	7.74
240	320	38	76	2.1	1.1	193	255	19 600	26 000	1 800	2 400	7948	100	8.34
260	360	46	92	2.1	1.1	258	375	26 300	38 000	1 700	2 200	7952	112	14
280	380	46	92	2.1	1.1	261	385	26 600	39 500	1 500	2 100	7956	118	14.8
300	420	56	112	3	1.1	325	520	33 500	53 000	1 400	1 900	7960	132	23.7

1) Bearing numbers appended with the code "B" have a contact angle of 40°; bearings with this code have a contact angle of 30°.
 2) Smallest allowable dimension for chamfer dimension r or ra.

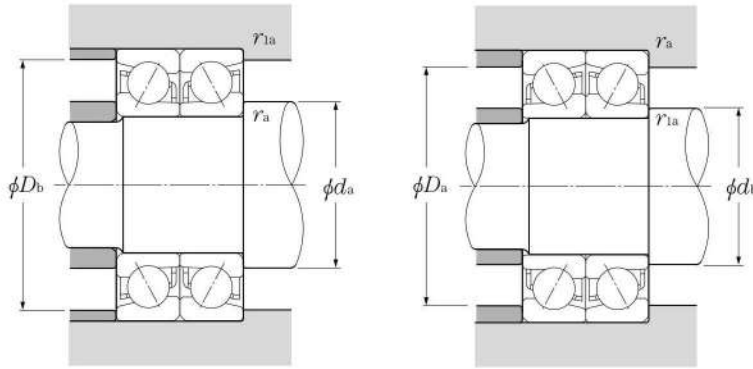

Dynamic equivalent radial load

$$P_r = XF_r + YF_a$$

Contact angle	e	Single, DT				DB, DF			
		$F_a/F_r \leq e$		$F_a/F_r > e$		$F_a/F_r \leq e$		$F_a/F_r > e$	
		X	Y	X	Y	X	Y	X	Y
30°	0.80	1	0	0.39	0.76	1	0.78	0.63	1.24
40°	1.14	1	0	0.35	0.57	1	0.55	0.57	0.93

Static equivalent radial load

$$P_{or} = X_o F_r + Y_o F_a$$

Contact angle	Single, DT		DB, DF	
	X_o	Y_o	X_o	Y_o
30°	0.5	0.33	1	0.66
40°	0.5	0.26	1	0.52

For single and DT arrangement,
When $P_{or} < F_r$ use $P_{or} = F_r$

Basic load ratings				Limiting speeds		Bearing numbers ¹⁾			Abutment and fillet dimensions				
dynamic (duplex) kN	static C_{or}	dynamic (duplex) kgf	static C_{or}	(duplex) min^{-1}		DB	DF	DT	mm				
C_r	C_{or}	C_r	C_{or}	grease	oil				d_a min	D_a max	D_b max	r_{1as} max	r_{1as} max
575	890	59 000	90 500	1 400	1 800	DB	DF	DT	188	342	351.5	3	1.5
213	325	21 700	33 500	2 000	2 700	DB	DF	DT	190	240	244.5	2	1
355	530	36 500	54 000	1 900	2 500	DB	DF	DT	192	268	273	2	1
495	770	50 500	78 500	1 700	2 200	DB	DF	DT	198	302	311.5	3	1.5
450	700	45 500	71 000	1 400	1 900	DB	DF	DT	198	302	311.5	3	1.5
665	1 070	68 000	109 000	1 500	2 000	DB	DF	DT	198	362	371.5	3	1.5
605	975	62 000	99 500	1 300	1 700	DB	DF	DT	198	362	371.5	3	1.5
216	335	22 000	34 500	1 900	2 500	DB	DF	DT	200	250	254.5	2	1
365	560	37 000	57 000	1 800	2 300	DB	DF	DT	202	278	283	2	1
495	780	50 000	79 500	1 600	2 100	DB	DF	DT	208	322	331.5	3	1.5
445	705	45 000	72 000	1 400	1 800	DB	DF	DT	208	322	331.5	3	1.5
695	1 170	71 000	119 000	1 400	1 900	DB	DF	DT	212	378	390	4	2
635	1 070	64 500	109 000	1 200	1 600	DB	DF	DT	212	378	390	4	2
300	465	30 500	47 000	1 800	2 400	DB	DF	DT	212	268	273	2	1
410	650	41 500	66 000	1 700	2 200	DB	DF	DT	212	298	303	2	1
550	900	56 000	92 000	1 500	2 000	DB	DF	DT	218	342	351.5	3	1.5
495	815	50 500	83 000	1 300	1 700	DB	DF	DT	218	342	351.5	3	1.5
730	1 210	74 500	124 000	1 300	1 800	DB	DF	DT	222	398	410	4	2
665	1 110	68 000	113 000	1 200	1 500	DB	DF	DT	222	398	410	4	2
305	475	31 000	48 500	1 600	2 100	DB	DF	DT	232	288	293	2	1
315	510	32 000	52 000	1 500	1 900	DB	DF	DT	252	308	313	2	1
420	750	42 500	76 500	1 300	1 800	DB	DF	DT	272	348	353	2	1
425	775	43 000	79 000	1 200	1 600	DB	DF	DT	292	368	373	2	1
530	1 040	54 000	106 000	1 100	1 500	DB	DF	DT	314	406	413	2.5	1

QJ type

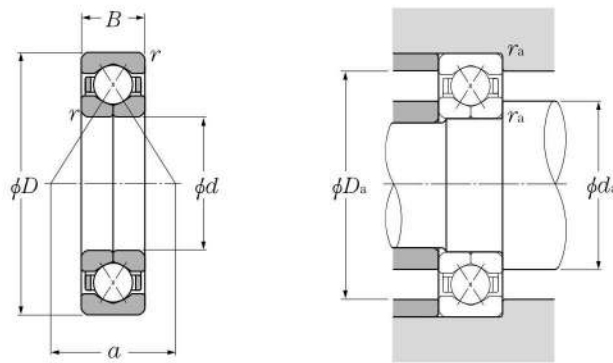

Dynamic equivalent axial load
 $P_a = F_a$
Static equivalent axial load
 $P_{0a} = F_a$

d 30 ~ 90mm

Boundary dimensions	Basic load ratings				Limiting speeds		Bearing numbers	Abutment and fillet dimensions			Load center	Mass			
	mm				min ⁻¹			mm							
d	D	B	$r_{s \min}^{1)}$	dynamic kN	static kN	dynamic kgf	static kgf	grease	oil	d_a min	D_a max	r_{as} max	a	(approx.) kg	
30	72	19	1.1	39.5	57.5	4 050	5 850	8 000	11 000	QJ306	37	65	1	30	0.42
35	80	21	1.5	49.5	73.0	5 050	7 450	7 000	9 300	QJ307	43.5	71.5	1.5	33	0.57
40	80	18	1.1	44.0	70.5	4 500	7 200	6 900	9 200	QJ208	47	73	1	34.5	0.45
	90	23	1.5	60.5	91.5	6 200	9 350	6 200	8 200	QJ308	48.5	81.5	1.5	37.5	0.78
45	85	19	1.1	49.5	81.0	5 050	8 250	6 200	8 200	QJ209	52	78	1	37.5	0.52
	100	25	1.5	79.0	121	8 050	12 300	5 500	7 400	QJ309	53.5	91.5	1.5	42	1.05
50	90	20	1.1	52.0	89.0	5 300	9 050	5 600	7 500	QJ210	57	83	1	40.5	0.603
	110	27	2	92.0	145	9 400	14 700	5 000	6 700	QJ310	60	100	2	46	1.38
55	100	21	1.5	64.0	112	6 550	11 400	5 100	6 800	QJ211	63.5	91.5	1.5	44.5	0.78
	120	29	2	106	170	10 900	17 400	4 600	6 100	QJ311	65	110	2	50.5	1.76
60	110	22	1.5	77.5	138	7 900	14 000	4 700	6 300	QJ212	68.5	101.5	1.5	49	0.98
	130	31	2.1	122	198	12 400	20 200	4 200	5 700	QJ312	72	118	2	55	2.18
65	120	23	1.5	84.5	153	8 600	15 600	4 400	5 800	QJ213	73.5	111.5	1.5	53.5	1.24
	140	33	2.1	138	228	14 100	23 200	3 900	5 200	QJ313	77	128	2	59	2.7
70	125	24	1.5	92.0	168	9 350	17 200	4 000	5 400	QJ214	78.5	116.5	1.5	56.5	1.36
	150	35	2.1	155	260	15 800	26 500	3 600	4 800	QJ314	82	138	2	63.5	3.27
75	130	25	1.5	96.0	183	9 750	18 600	3 800	5 000	QJ215	83.5	121.5	1.5	59	1.53
	160	37	2.1	169	294	17 200	30 000	3 400	4 500	QJ315	87	148	2	68	3.9
80	140	26	2	112	217	11 400	22 100	3 500	4 700	QJ216	90	130	2	63.5	1.83
	170	39	2.1	183	330	18 600	33 500	3 200	4 200	QJ316	92	158	2	72	4.64
85	150	28	2	126	252	12 800	25 700	3 300	4 400	QJ217	95	140	2	68	2.3
	180	41	3	197	370	20 100	37 500	3 000	4 000	QJ317	99	166	2.5	76.5	5.43
90	160	30	2	148	293	15 100	29 900	3 100	4 200	QJ218	100	150	2	72	2.76
	190	43	3	212	410	21 600	41 500	2 800	3 800	QJ318	104	176	2.5	81	6.31

1) Smallest allowable dimension for chamfer dimension r.

Note: 1. These bearings are also manufactured with a slot in the chamfer section of the outer ring to stop whirling.

2. This bearing is widely used in applications where the only type of load is axial. When considering it for use where radial loads are applied, consult MBR Engineering.

QJ type

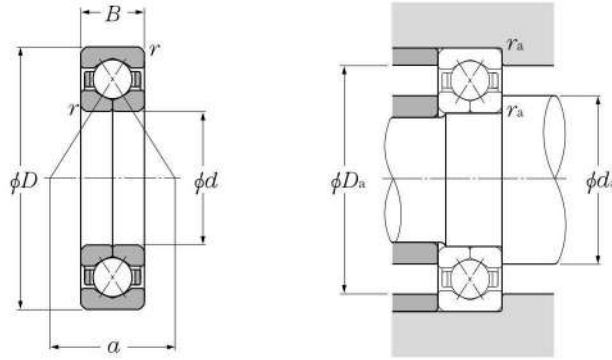

Dynamic equivalent axial load
 $P_a = F_a$
Static equivalent axial load
 $P_{0a} = F_a$

d 95 ~ 120mm

	Boundary dimensions			Basic load ratings				Limiting speeds		Bearing numbers	Abutment and fillet dimensions			Load center	Mass
	mm			dynamic	static	dynamic	static	min ⁻¹			mm				
	d	D	B	$r_{s \min}^{1)}$	C_a	C_{0a}	C_a	C_{0a}	grease	oil	d_a	D_a	r_{as}	a	(approx.)
95	170	32	2.1	168	335	17 200	34 000	3 000	3 900	QJ219	107	158	2	76.5	3.35
	200	45	3	227	450	23 100	46 000	2 700	3 500	QJ319	109	186	2.5	85	7.41
100	180	34	2.1	181	355	18 400	36 000	2 800	3 700	QJ220	112	168	2	81	4.02
	215	47	3	273	585	27 800	59 500	2 500	3 400	QJ320	114	201	2.5	91	9.14
105	190	36	2.1	197	400	20 100	41 000	2 700	3 600	QJ221	117	178	2	85	4.75
	225	49	3	273	585	27 900	59 500	2 400	3 200	QJ321	119	211	2.5	95.5	10.4
110	200	38	2.1	213	450	21 700	45 500	2 500	3 400	QJ222	122	188	2	89.5	5.62
	240	50	3	305	680	31 000	69 500	2 300	3 100	QJ322	124	226	2.5	101	12
120	215	40	2.1	240	540	24 500	55 000	2 300	3 100	QJ224	132	203	2	96.5	6.75
	260	55	3	325	765	33 000	78 000	2 100	2 800	QJ324	134	246	2.5	110	15.9

1) Smallest allowable dimension for chamfer dimension r.

Note: 1. These bearings are also manufactured with a slot in the chamfer section of the outer ring to stop whirling.

2. This bearing is widely used in applications where the only type of load is axial. When considering it for use where radial loads are applied, consult MBR Engineering.

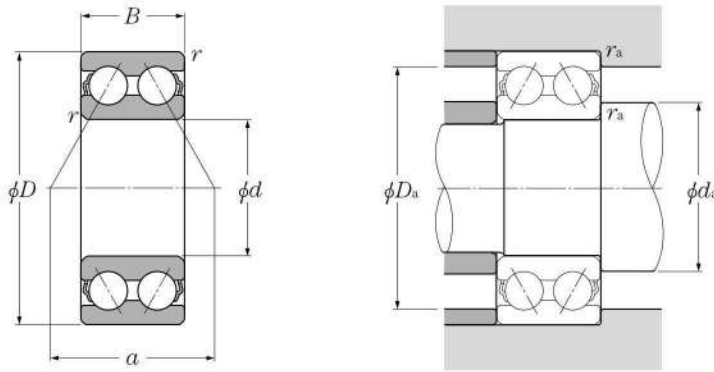

Dynamic equivalent radial load

$$P_r = X F_r + Y F_a$$

e	$\frac{F_a}{F_r} \leq e$		$\frac{F_a}{F_r} > e$	
	X	Y	X	Y
0.68	1	0.92	0.67	1.41

Static equivalent radial load

$$P_{or} = F_r + 0.76 F_a$$

d 10 ~ 65mm

d	Boundary dimensions			Basic load ratings				Limiting speeds		Bearing numbers	Abutment and fillet dimensions			Load center	Mass
	mm			dynamic	static	dynamic	static	min ⁻¹			mm				
	D	B	$r_{s, \min}^{1)}$	C_r	C_{or}	C_r	C_{or}	grease	oil		d_a	D_a	r_{as}		
10	30	14.3	0.6	7.15	3.90	730	400	17 000	22 000	5200S	15	25	0.6	14.5	0.05
12	32	15.9	0.6	10.5	5.80	1 070	590	15 000	20 000	5201S	17	27	0.6	16.7	0.06
15	35	15.9	0.6	11.7	7.05	1 190	715	13 000	17 000	5202S	20	30	0.6	18.3	0.07
	42	19	1	17.6	10.2	1 800	1 040	11 000	15 000	5302S	21	36	1	22.0	0.11
17	40	17.5	0.6	14.6	9.05	1 490	920	11 000	15 000	5203S	22	35	0.6	20.8	0.09
	47	22.2	1	21.0	12.6	2 140	1 280	10 000	13 000	5303S	23	41	1	25.0	0.14
20	47	20.6	1	19.6	12.4	2 000	1 270	10 000	13 000	5204S	26	41	1	24.3	0.12
	52	22.2	1.1	24.6	15.0	2 510	1 530	9 000	12 000	5304S	27	45	1	26.7	0.23
25	52	20.6	1	21.3	14.7	2 170	1 500	8 500	11 000	5205S	31	46	1	26.8	0.19
	62	25.4	1.1	32.5	20.7	3 350	2 110	7 500	10 000	5305S	32	55	1	31.8	0.34
30	62	23.8	1	29.6	21.1	3 000	2 150	7 100	9 500	5206S	36	56	1	31.6	0.29
	72	30.2	1.1	40.5	28.1	4 150	2 870	6 300	8 500	5306S	37	65	1	36.5	0.51
35	72	27	1.1	39.0	28.7	4 000	2 920	6 300	8 000	5207S	42	65	1	36.6	0.43
	80	34.9	1.5	51.0	36.0	5 200	3 700	5 600	7 500	5307S	44	71	1.5	41.6	0.79
40	80	30.2	1.1	44.0	33.5	4 500	3 400	5 600	7 100	5208S	47	73	1	41.5	0.57
	90	36.5	1.5	56.5	41.0	5 800	4 200	5 300	6 700	5308S	49	81	1.5	45.5	1.05
45	85	30.2	1.1	49.5	38.0	5 050	3 900	5 000	6 700	5209S	52	78	1	43.4	0.62
	100	39.7	1.5	68.5	51.0	7 000	5 200	4 500	6 000	5309S	54	91	1.5	50.6	1.40
50	90	30.2	1.1	53.0	43.5	5 400	4 400	4 800	6 000	5210S	57	83	1	45.9	0.67
	110	44.4	2	81.5	61.5	8 300	6 250	4 300	5 600	5310S	60	100	2	55.6	1.95
55	100	33.3	1.5	56.0	49.0	5 700	5 000	4 300	5 600	5211S	64	91	1.5	50.1	0.96
	120	49.2	2	95.0	73.0	9 700	7 450	3 800	5 000	5311S	65	110	2	60.6	2.30
60	110	36.5	1.5	69.0	62.0	7 150	6 300	3 800	5 000	5212S	69	101	1.5	56.5	1.35
	130	54	2.1	125	98.5	12 800	10 000	3 400	4 500	5312S	72	118	2	69.2	3.15
65	120	38.1	1.5	76.5	69.0	7 800	7 050	3 600	4 500	5213S	74	111	1.5	59.7	1.65
	140	58.7	2.1	142	113	14 500	11 500	3 200	4 300	5313S	77	128	2	72.8	3.85

1) Smallest allowable dimension for chamfer dimension r.

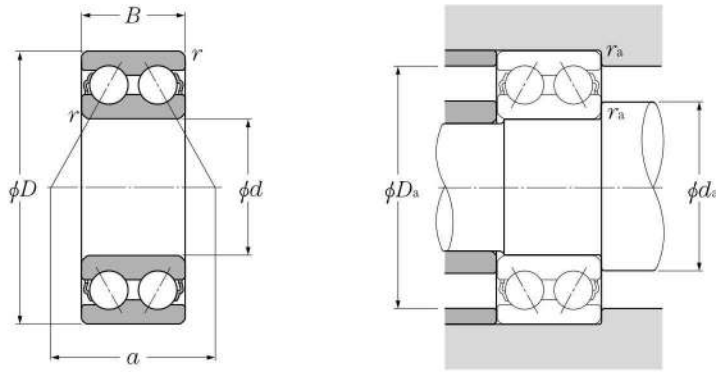

Dynamic equivalent radial load

$$P_r = X F_r + Y F_a$$

e	$\frac{F_a}{F_r} \leq e$		$\frac{F_a}{F_r} > e$	
	X	Y	X	Y
0.68	1	0.92	0.67	1.41

Static equivalent radial load

$$P_{or} = F_r + 0.76 F_a$$

d 70 ~ 85mm

d	Boundary dimensions				Basic load ratings				Limiting speeds		Bearing numbers	Abutment and fillet dimensions			Load center mm	Mass kg
	mm				dynamic kN		static kgf		min ⁻¹			mm				
	D	B	r _{s min} ¹⁾	r	C _r	C _{or}	C _r	C _{or}	grease	oil		d _{a min}	D _{a max}	r _{as max}		
70	125	39.7	1.5	94.0	82.0	9 600	8 400	3 400	4 500	5214S	79	116	1.5	63.8	1.80	
	150	63.5	2.1	159	128	16 200	13 100	3 000	3 800	5314S	82	138	2	78.3	4.90	
75	130	41.3	1.5	93.5	83.0	9 550	8 500	3 200	4 300	5215S	84	121	1.5	66.1	1.90	
80	140	44.4	2	99.0	93.0	10 100	9 500	3 000	3 800	5216S	90	130	2	69.6	2.50	
85	150	49.2	2	116	110	11 800	11 200	2 800	3 600	5217S	95	140	2	75.3	3.40	

1) Smallest allowable dimension for chamfer dimension r.

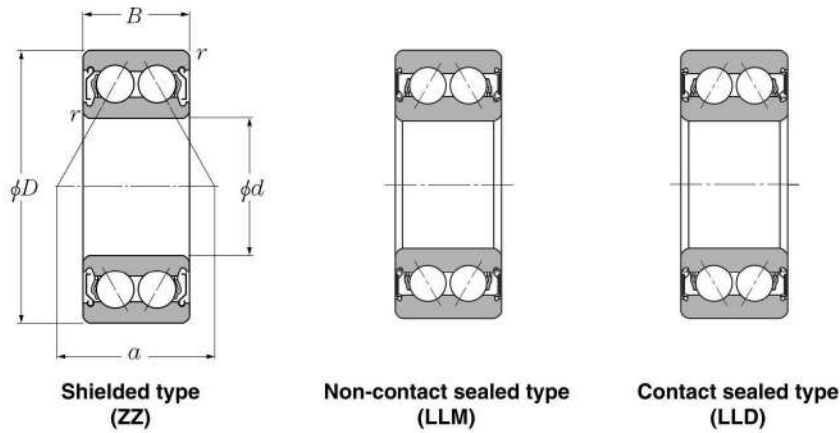

d 10 ~ 40mm

d	Boundary dimensions			Basic load ratings				Limiting speeds			Bearing numbers ²⁾		
	mm			dynamic	static	dynamic	static	min ⁻¹		oil Z,LM	sealed		
	D	B	r _s mm ¹⁾	C _r	C _{or}	C _r	C _{or}	grease ZZ,LLM	LLD		non-contact type	contact type	
10	30	14.3	0.6	7.15	3.90	730	400	17 000	15 000	22 000	5200SCZZ	LLM	LLD
12	32	15.9	0.6	8.50	5.30	865	540	15 000	12 000	20 000	5201SCZZ	LLM	LLD
15	35	15.9	0.6	8.50	5.30	865	540	13 000	12 000	17 000	5202SCZZ	LLM	LLD
17	40	17.5	0.6	12.7	8.30	1 290	850	11 000	10 000	15 000	5203SCZZ	LLM	LLD
	47	22.2	1	19.6	12.4	2 000	1 270	10 000	9 500	13 000	5303SCZZ	LLM	LLD
20	47	20.6	1	15.9	10.7	1 620	1 090	10 000	9 000	13 000	5204SCZZ	LLM	LLD
25	52	20.6	1	16.9	12.3	1 730	1 260	8 500	7 500	11 000	5205SCZZ ³⁾	LLM	LLD
	62	25.4	1.1	25.2	18.2	2 570	1 850	7 500	6 300	10 000	5305SCZZ	LLM	LLD
30	62	23.8	1	25.2	18.2	2 570	1 850	7 100	6 300	9 500	5206SCZZ	LLM	LLD
	72	30.2	1.1	39.0	28.7	4 000	2 920	6 300	5 300	8 500	5306SCZZ	LLM	LLD
35	72	27.0	1.1	34.0	25.3	3 500	2 580	6 300	5 300	8 500	5207SCZZ	LLM	LLD
	80	34.9	1.5	44.0	33.5	4 500	3 400	5 600	4 800	7 500	5307SCZZ	LLM	LLD
40	80	30.2	1.1	36.5	29.0	3 700	2 960	5 600	4 800	7 100	5208SCZZ ³⁾	LLM	LLD
	90	36.5	1.5	49.5	38.0	5 050	3 900	5 300	4 500	6 700	5308SCZZ	LLM	LLD

1) Smallest allowable dimension for chamfer dimension r.

2) This bearing number is for double sealed and double shielded type bearings, but single sealed and single shielded type are also available.

3) Resin formed cage is standard for 5205SC and 5208SC.

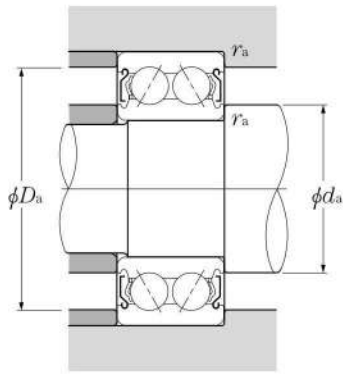

Dynamic equivalent radial load

$$P_r = X F_r + Y F_a$$

e	$\frac{F_a}{F_r} \leq e$		$\frac{F_a}{F_r} > e$	
	X	Y	X	Y
0.68	1	0.92	0.67	1.41

Static equivalent radial load

$$P_{0r} = F_r + 0.76 F_a$$

Abutment and fillet dimensions				Load center mm
mm				
	d_a	D_a	r_{as}	a
min	max	max	max	
14	15.5	26	0.6	14.5
16	19.0	28	0.6	16.3
19	19.0	31	0.6	16.3
21	23.5	36	0.6	20.1
23	25.5	41	1	24.3
26	26.5	41	1	23.0
31	32.0	46	1	25.4
32	38.5	55	1	30.9
36	38.5	56	1	30.9
37	44.5	65	1	36.6
42	45.0	65	1	36.3
44	50.5	71	1.5	41.5
47	50.5	73	1	39.4
49	53.0	81	1.5	43.0

